

HOUSING FOR STRAIGHT JACK

R197.132.H90

Series : **SMB CARLOCK**

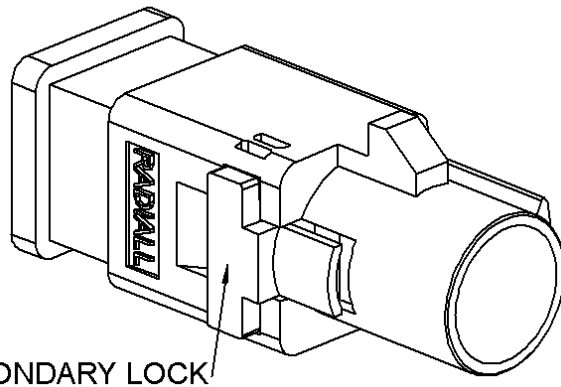
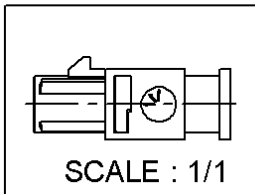
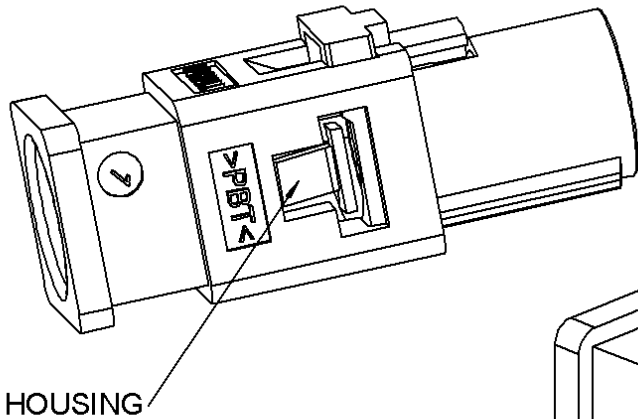
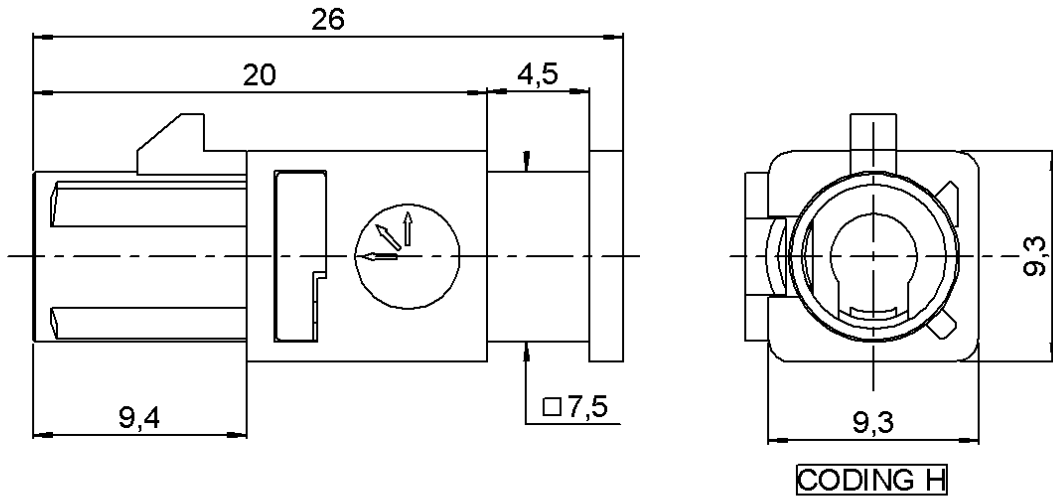

All dimensions are in mm.

COMPONENTS		MATERIALS	PLATINGS (µm)	
HOUSING	PBT		UL CLASSIFICATION	COLOR
SECONDARY LOCK	PBT		UL 94 V-2	VIOLET Ral 4003
			UL 94 V-2	PURPLE Ral4006
			*According to FAKRA specifications	

Issue : 0334 A

In the effort to improve our products, we reserve the right to make changes judged to be necessary.



HOUSING FOR STRAIGHT JACK

R197.132.H90

Series : **SMB CARLOCK**

PACKAGING

SPECIFICATION

Standard	Unit	Other
100	'W' option	Contact us

QS9000

ELECTRICAL CHARACTERISTICS

ENVIRONMENTAL

Impedance		Ω
Frequency		GHz
VSWR	+ 0.000	x F(GHz) Maxi
Insertion loss		\sqrt{F} (GHz) dB Maxi
RF leakage	- (- F(GHz)) dB Maxi
Voltage rating		Veff Maxi
Dielectric withstanding voltage		Veff mini
Insulation resistance		M Ω mini

Operating temperature	-40/+110	$^{\circ}$ C
Hermetic seal		Atm.cm3/s
Panel leakage		

OTHERS CHARACTERISTICS

Assembly instruction **Page 3 & 4**

Others :

HOUSING FOR COAX
R114.242.325,R114.246.325,R114.249.325

MECHANICAL CHARACTERISTICS

Center contact retention		
Axial force – Mating end		N mini
Axial force – Opposite end		N mini
Torque		N.cm mini
Recommended torque		
Mating		N.cm
Panel nut		N.cm
Mating life	100	Cycles mini
Weight	1.241	g

Issue : 0334 A

In the effort to improve our products, we reserve the right to make changes judged to be necessary.



HOUSING FOR STRAIGHT JACK

R197.132.H90

Series : SMB CARLOCK

RECOMMENDED MOUNTING PROCEDURE

1

- Push the coax until it stops at the bottom of the housing

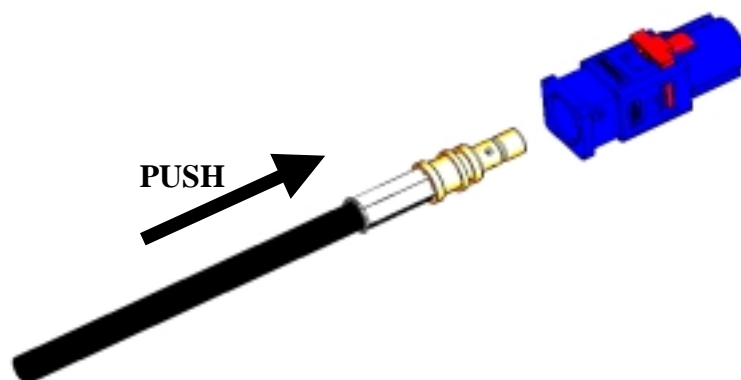

2

- Push the secondary lock in final position to secure the coax inside the housing (until it click on)

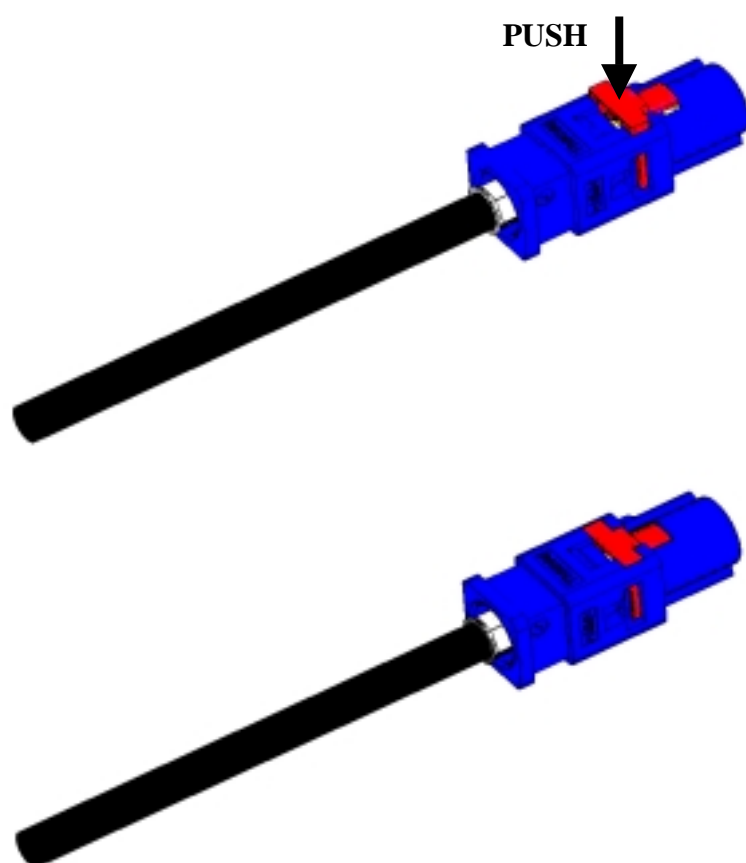

Issue : 0334 A

In the effort to improve our products, we reserve the right to make changes judged to be necessary.



HOUSING FOR STRAIGHT JACK

R197.132.H90

Series : SMB CARLOCK

RECOMMENDED DISASSEMBLING PROCEDURE

1

- insert a screw driver into the slot of the CPA devise as shown on the picture.
- Tip up the screw driver as shown on the picture to lift up the CPA devise until it click on.

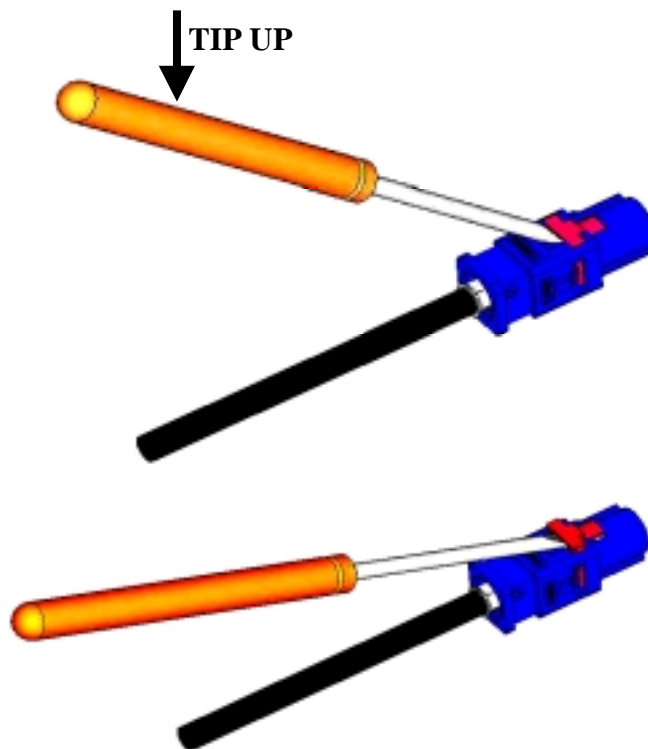

2

- insert a screw driver between the elastic finger and the CPA devise as shown on the picture.
- Tip up the screw driver as shown on the picture to lift up the elastic finger and when it is done pull on the cable assembly to remove the coax from the housing.

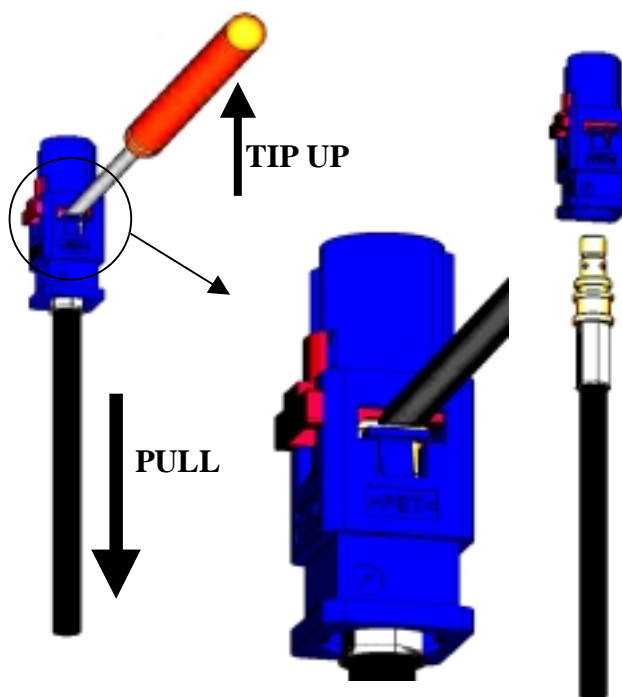

Issue : 0334 A

In the effort to improve our products, we reserve the right to make changes judged to be necessary.